



Bi-Folding Door

Installation Guide

1. Your Door
2. Checking Your Delivery
3. Assembling the Outer-frame with a standard (DV14) threshold
4. Assembling the Outer-frame with a low (DV171) threshold
5. Installing the Doors
 - A. Removal of Sashes
 - B. Fitting the Outer-frame
 - C. Refitting the Sashes
 - D. Glazing and Toe & Healing
 - E. Final fixings & Magnetic Catch



Scan to view the installation guide on your mobile or tablet

Your Door

You will either receive your door as a packaged assembled unit or it may be necessary to send the doors to you in kit form in certain circumstances.



An example of how your doors will arrive.

Checking your delivery

It is important that you check the doors over as soon as possible after they arrive. You have 24 hours in which to check the delivery for any damage and that the specification is correct to the order form which was signed. After this time it is possible that any damage or shortages reported will not be rectified at our cost.

Assembling the Outer-frame with a Standard (DV14) Threshold

Follow the steps in this section to assemble the outer-frame. This will only be required when your doors are delivered in kit form.

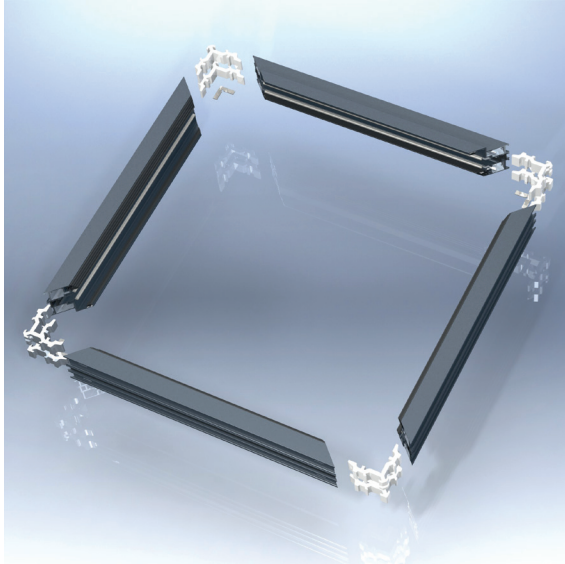

Door outer-frame laid out ready for assembly.

Lay the outer-frame out on a flat surface and remove the packaging. Be careful to ensure that there is no grit or debris on the surface where you plan to lay the profile out. Once the pieces are laid out and the packaging removed put the top, bottom, right and left pieces of outer-frame roughly in position.

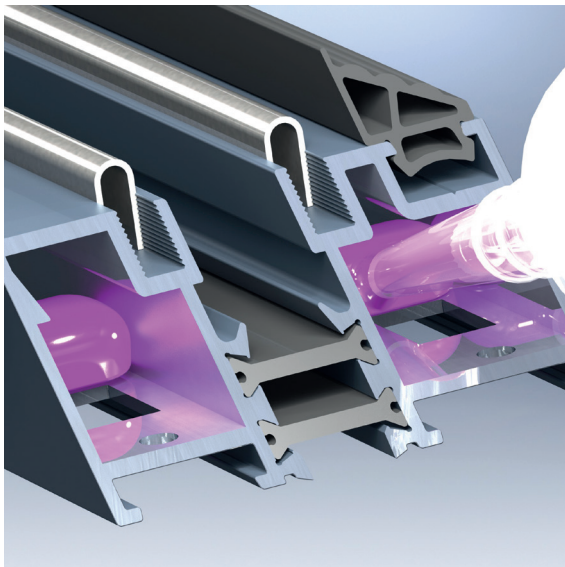

Outer-frame sections showing adhesive (shown in purple).

Using the adhesive provided, apply to the inside of the outer-frame section, just passed both the punched out holes. Do this to each end of all the sections of outer-frame.

Assembling the Outer-frame with a Standard (DV14) Threshold cont...

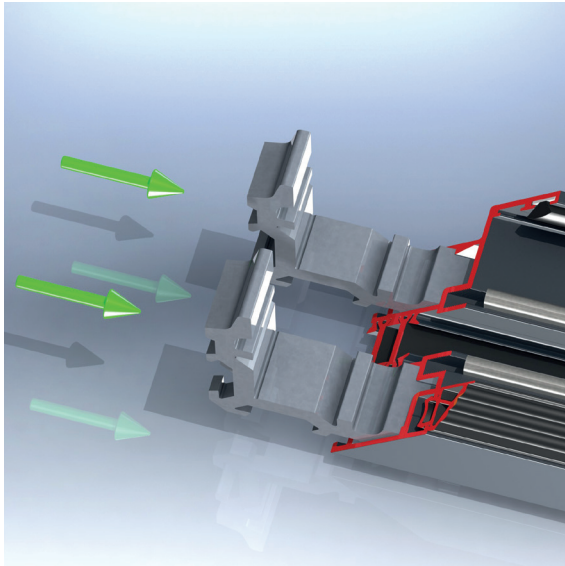

Inserting cleats into the outer-frame
(Red area shows application of silicone sealant)

Using silicone sealant, apply to the cross sectional faces of the profiles (see red area on the image to the left). Once applied, insert two cleats into each corner of the top and lower horizontal sections of outer-frame. The cleats are different widths; the wider of the two should be inserted to the door opening side and the narrower cleat to the rebated side.

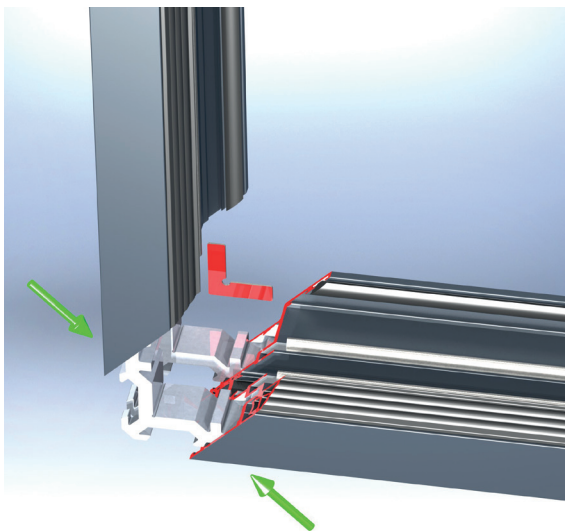

The corner chevron is required to help align the joint.

Once the cleats are fully inserted, position the chevron into the alignment slots as shown here in RED. Push the joints together. This is best done by fitting the left and right pieces of outer-frame to the bottom section followed by the fitting of the top piece.

Assembling the Outer-frame with a Standard (DV14) Threshold cont...

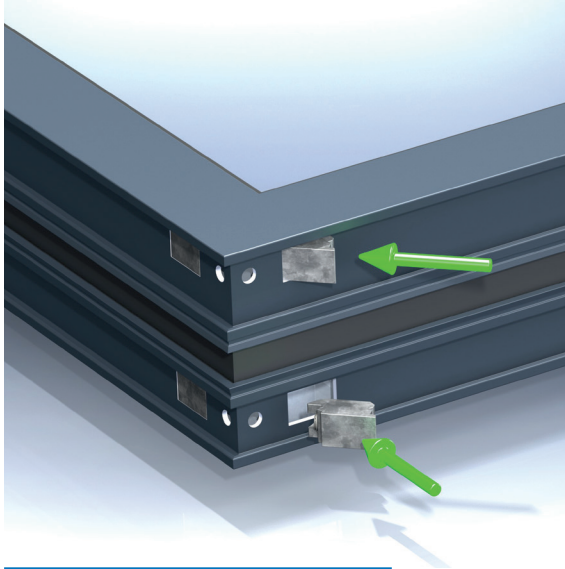

Cleat tensioning block inserted through punched holes in outer-frame

With the joint pushed together insert the cleat tensioning blocks into the four slots as shown. Make sure they are seated correctly before continuing.

Repeat this step for all four corners.

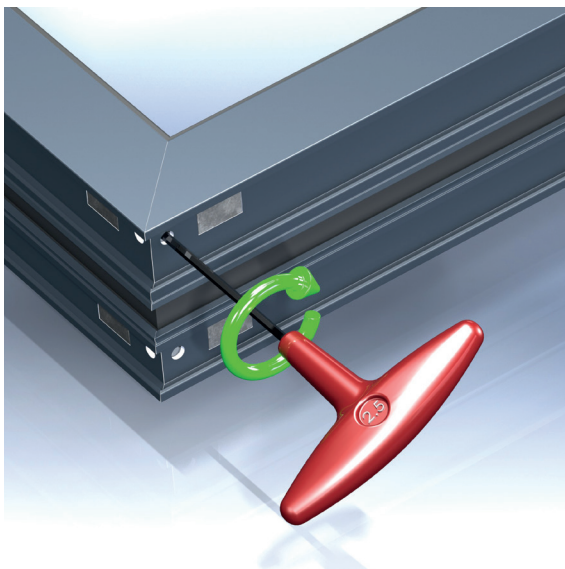

It is important that the cleat tensioning block screws are tightened sufficiently to secure the corner joint

Using a 2.5mm hex key, tighten each one in turn. You may find you need to slacken and re-tighten in order to make sure the joint is perfectly aligned. (This can be a bit tricky so take your time and don't be afraid to slacken and redo if required)

Make certain that all four cleat tensioning blocks are tight before moving on to the next corner.

Repeat this step for all the corners.

Assembling the Outer-frame with a Low (DV171) Threshold

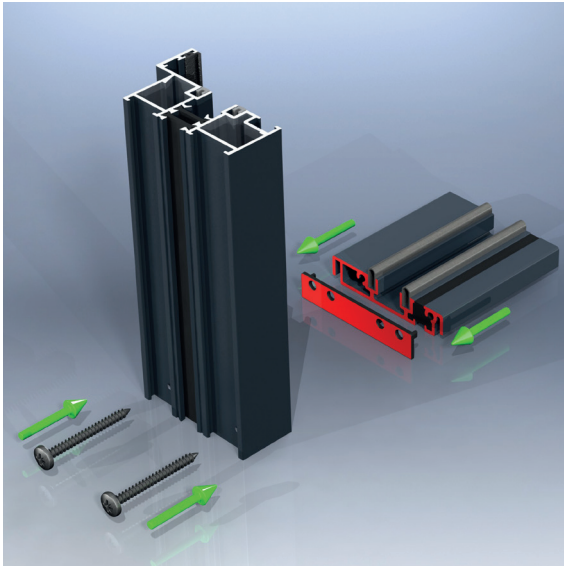

Exploded image of the DV171 low threshold joint to the outer-frame

Follow section 3 (Assembling the Outer-frame with a standard (DV14) Threshold) for the assembly of the top piece of outer-frame where it connects to the left and right hand sections.

For the low threshold section of outer-frame, apply silicone sealant to both sides of the end-caps and fit together as shown securing with the screws provided.

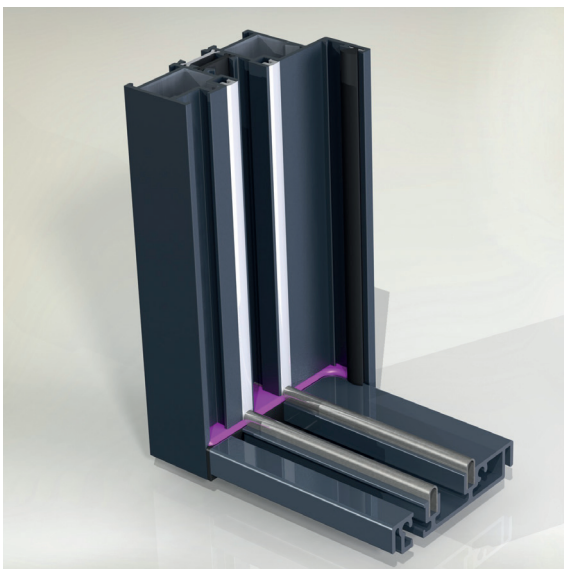

This is how the finished joint should appear. You may need to clean any excess silicone away once the joint is tightly together.

After the two screws are tightened, the finished joint should look like the image to the left.

Once both sides are secure, clean down the joint.

Installing the Doors



Removing these two screws for each hinge will allow the removal of the door sashes

A. Removing the Sashes

For handling reasons, we recommend that the outer-frame is installed without the sashes attached. This is to make it easier for the fitter to position and fix the outer-frame accurately.

To remove the sashes, undo the five screws on one side of all four hinges for each sash. After the hinges are detached, the sashes with the roller and guide need to be tilted to be removed.

Fix any make up pieces to the door outer-frame at this stage ensuring a bead of silicone is applied to seal the joint.

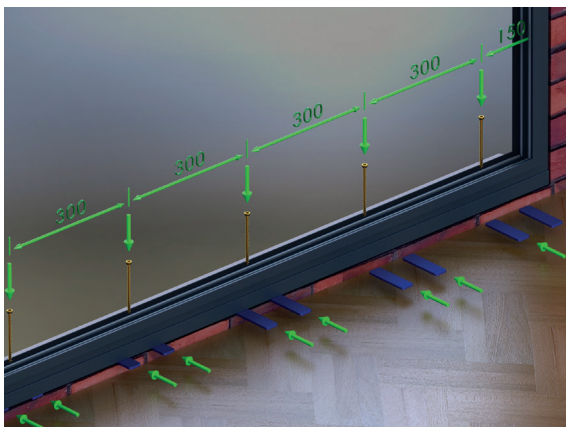

Use the above dimensions for your packing points and secure using concrete screws

B. Fitting the Outer-frame

If your door comes with a sill, fix it to the outer-frame before positioning it into the aperture. If you have opted for no sill then position the outer-frame into the opening.

Using a spirit level and tape measure, pack every 300mm around the outer-frame making sure it is level and plumb. Use a tape measure to check the diagonals are equal to ensure the outer-frame is square and use a plumb line to check all the sections of outer-frame are straight and not bowed.

Position the packers either side of the fixing screws so when tightened it doesn't pull the outer-frame and distort it.

Installing the Doors cont...

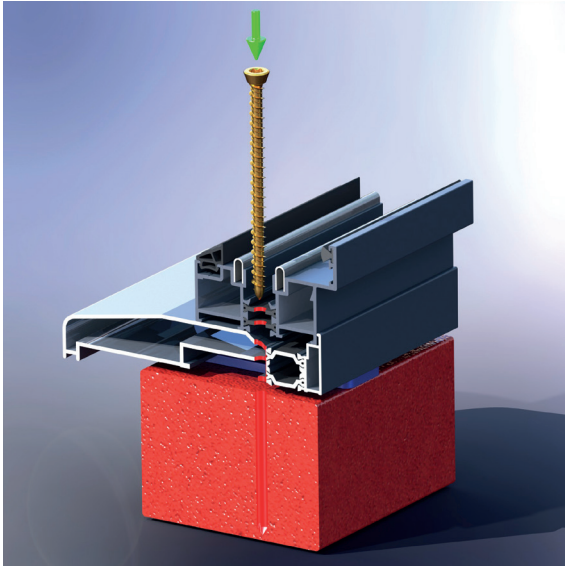

Once the door outer-frame is plumb, level and square, fix to the surrounding brick work. We recommend you fix through the thermal break using concrete screws.

Fixing of the doors

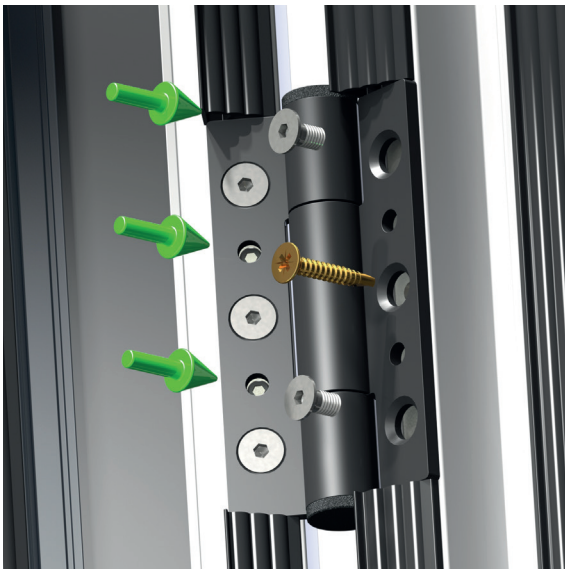

C. Refitting the Sashes

To refit the sashes, position each sash in turn into the outer-frame and re attach using the hex head machine screws and the central self tapping screw

These two screws secure the sashes

Installing the Doors cont...

D. Glazing and Toe & Heeling

Where shown
indicates
Area to pack

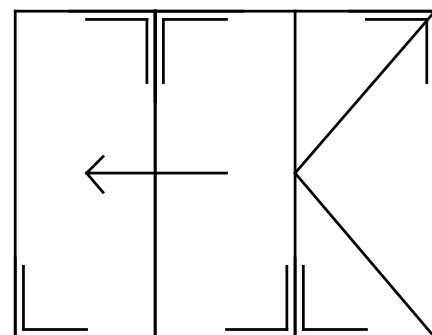
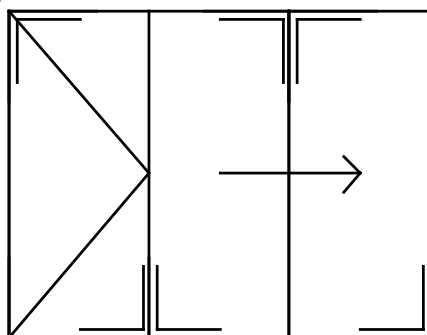
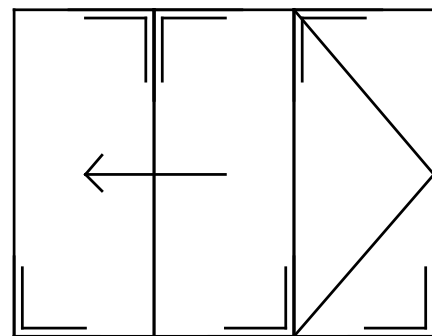
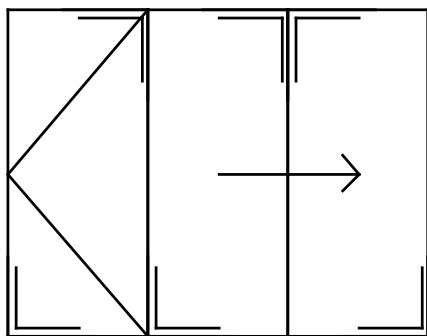
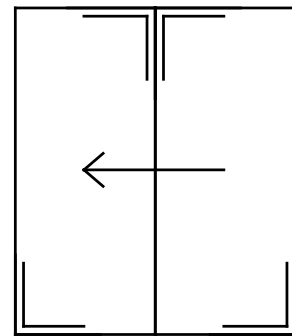
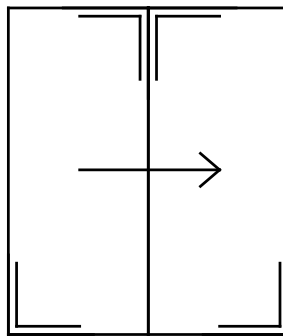
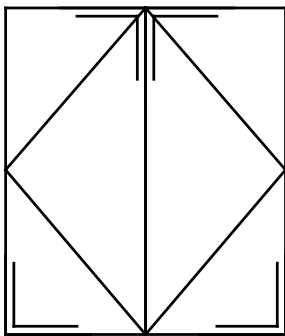
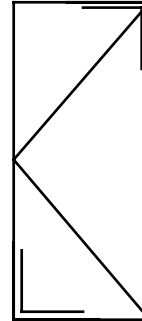
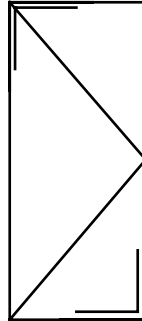

Installing the Doors cont...

D. Glazing and Toe & Heeling

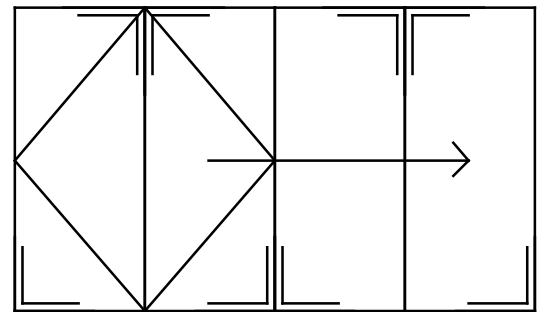
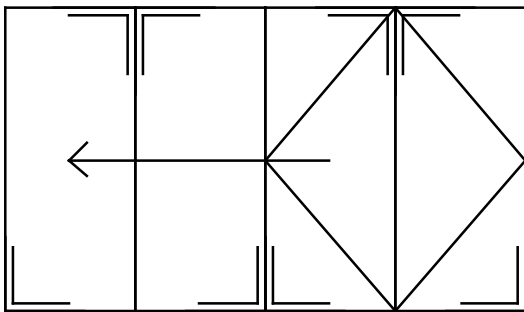
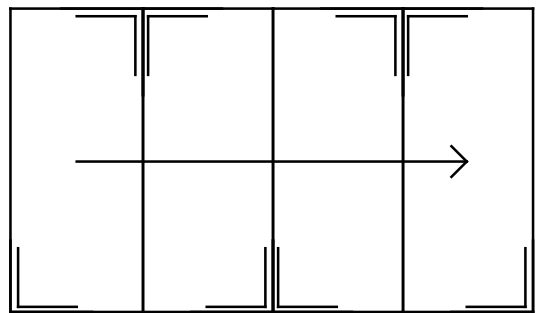
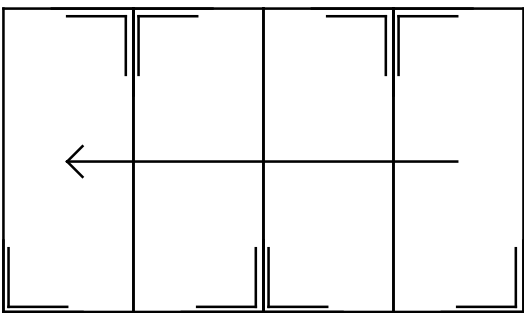
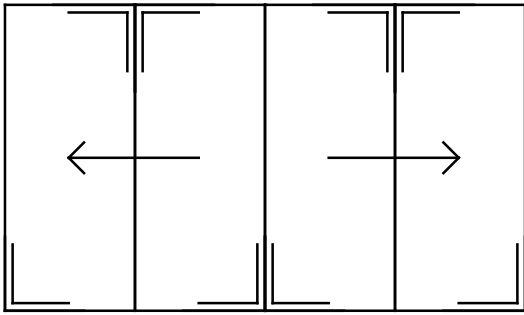

Installing the Doors cont...

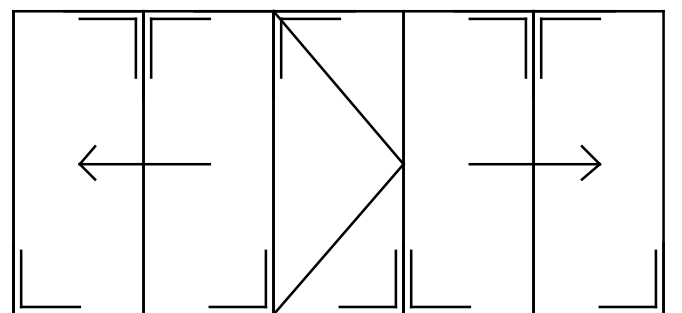
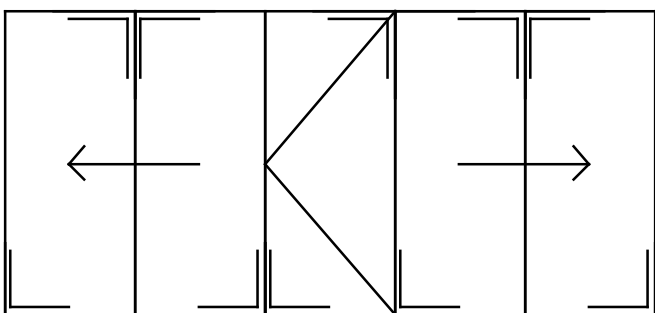
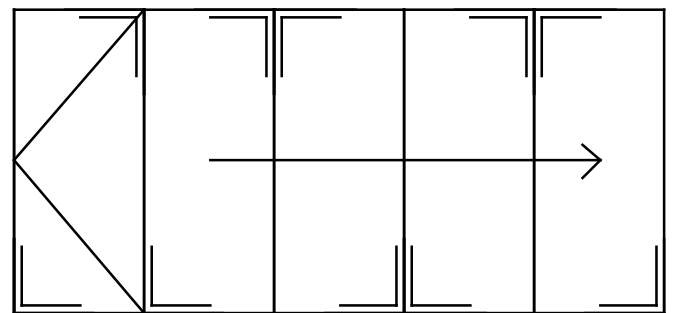
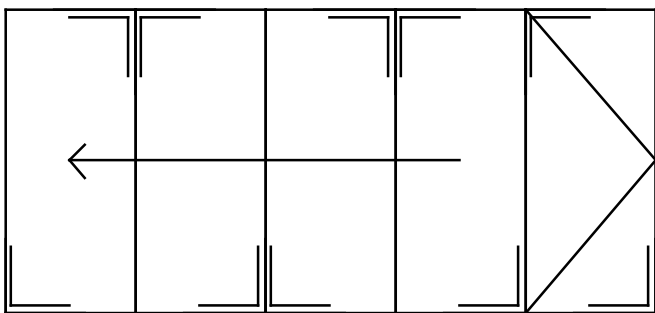
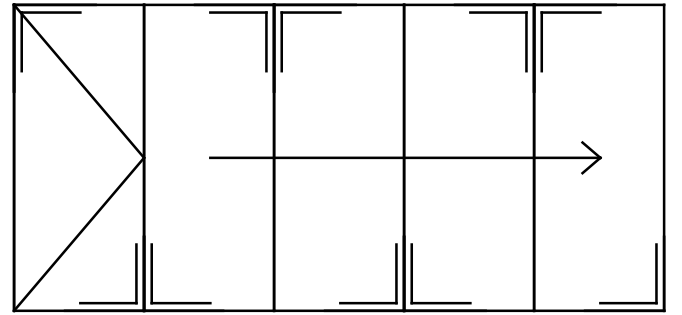
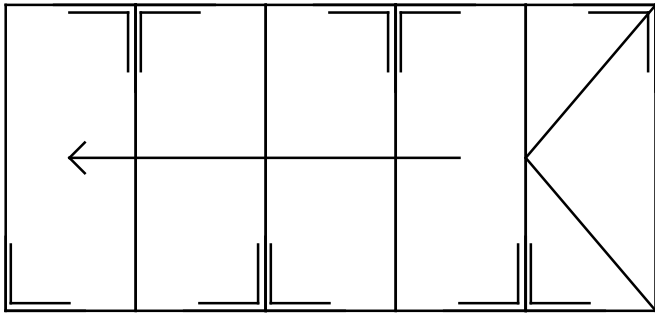

Installing the Doors cont...

D. Glazing and Toe & Heeling

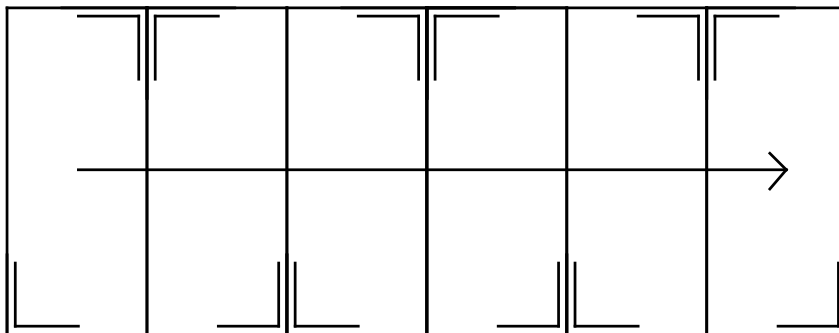
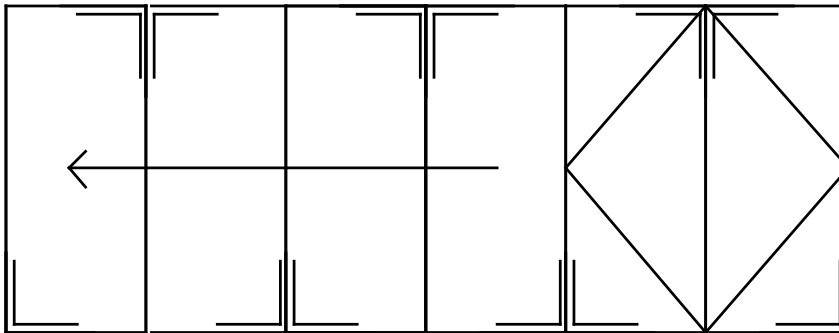
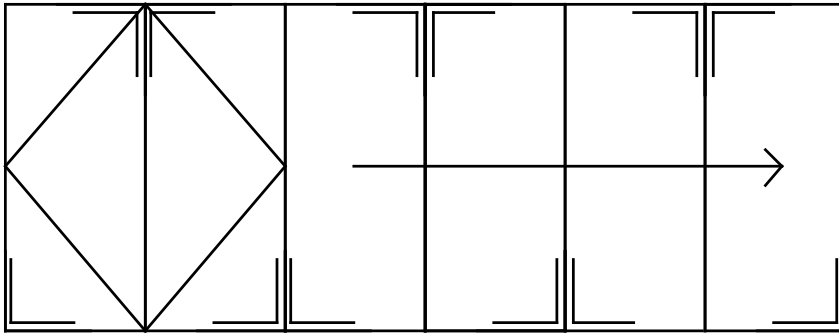
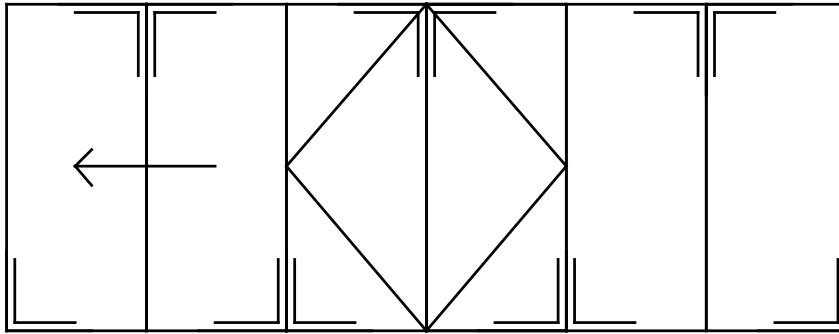

Installing the Doors cont...

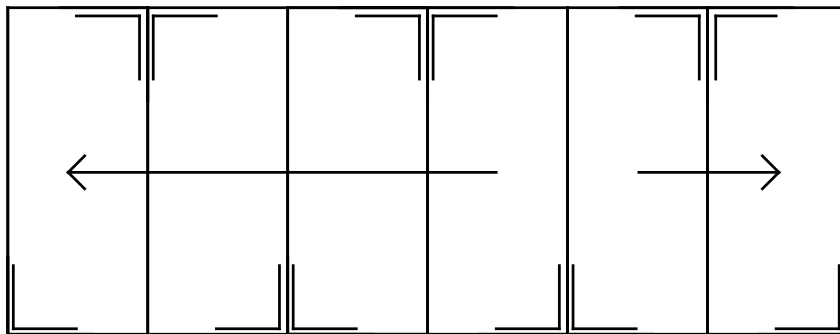
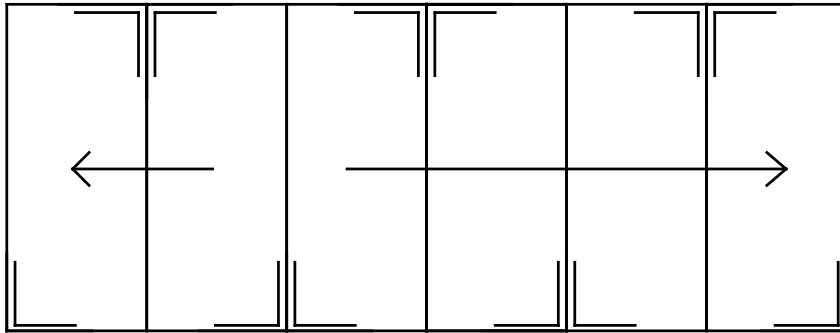
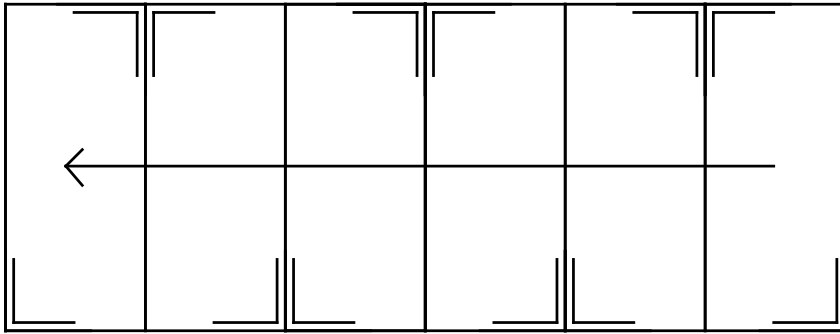

Installing the Doors cont...

E. Final fixings & Magnetic Catch



The wedge gasket is used to secure the glass firmly into the sashes and provide a seal

After you have toe and healed each sash and checked the operation, you will need to fit the glazing beads. To do this replace them in the same order they were removed and secure by fitting the glazing tear off gasket supplied.

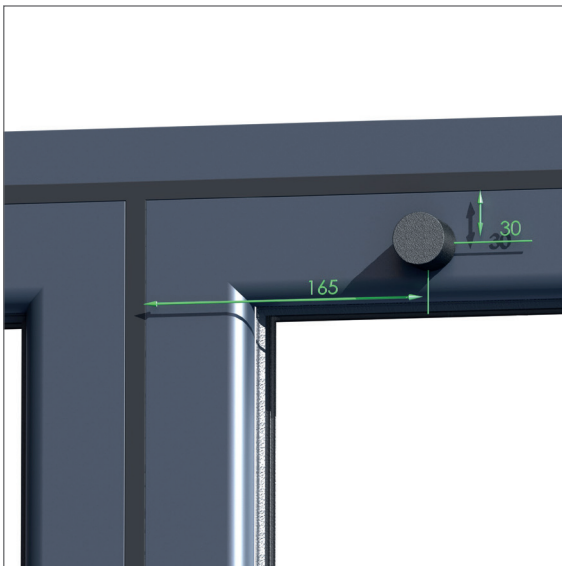

To stop the traffic door from swinging in the wind when open, there is a magnetic catch supplied.

Installing the Doors cont...

E. Final fixings & Magnetic Catch

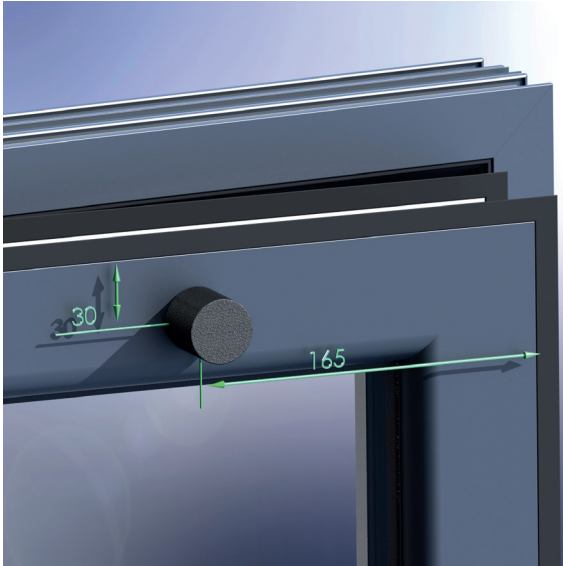

Following the instructions in the magnetic catch box, install one half 165mm in and 30mm down on the top of the opening end of the traffic door.

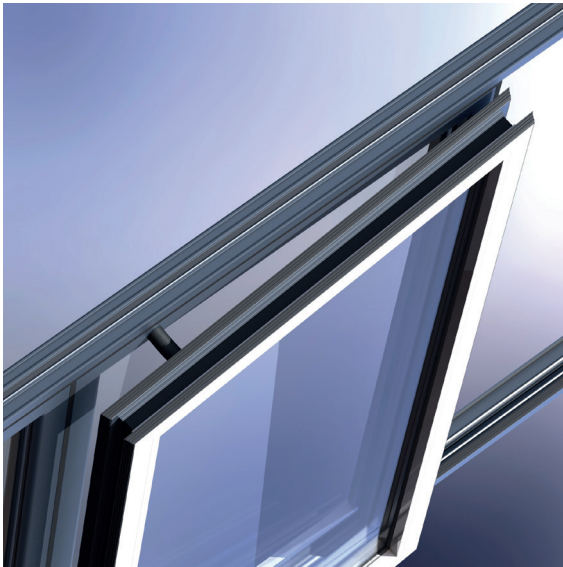

Install the other half in the same manner on the sash next to the traffic door so when fully open the two halves connect as shown opposite.

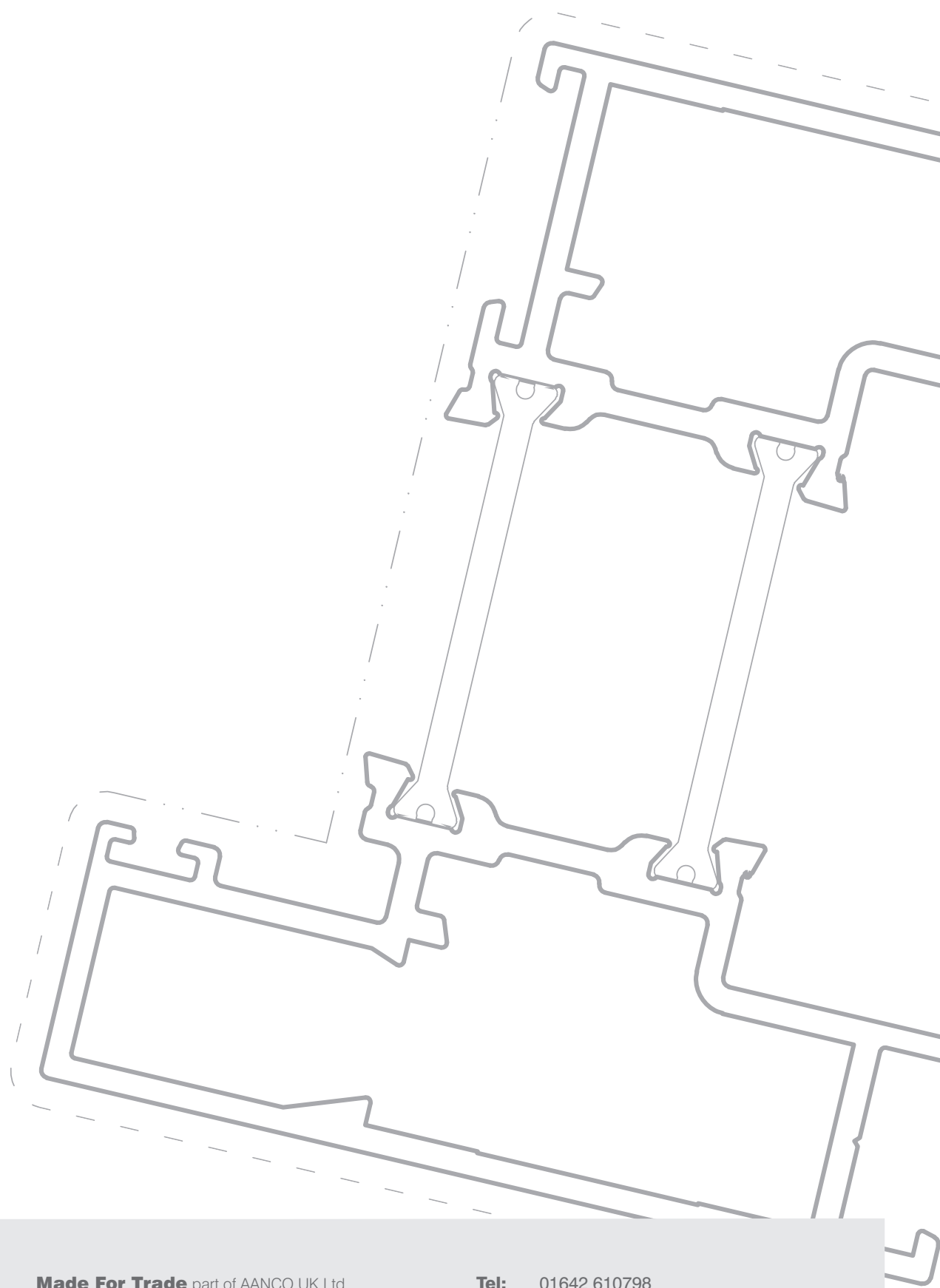

Made For Trade part of AANCO UK Ltd

Unit B20 Lustrum Avenue,
Portrack Lane,
Stockton - On - Tees
Cleveland. TS18 2RB

Tel: 01642 610798
Fax: 01642 671026
Email: sales@madefortrade.co

Web: www.madefortrade.co